

Demonstration: E5b Signal Containing Value-Added Information Broadcast in Real Time via the SES ASTRA 5B GEO Satellite

Marion Aubault-Roudier, Denis Laurichesse, *CNES, FRANCE*

Hanaa Al Bitar, Mathieu Raimondi, Pierre Lesage, Arnault Sfeir, Michael Klein, *THALES ALENIA SPACE, FRANCE*

Mathieu Sihrener, *ESSP, FRANCE*

Nicolas Ramponi, *SES Techcom, LUXEMBOURG*

BIOGRAPHY

Marion Aubault-Roudier is a RadioNavigation engineer in the navigation/location signals department at CNES, the French Space Agency, where she is involved in the optimization of GNSS signals as well as the assessment of GNSS user segments (receivers, algorithms). She graduated as an electronics engineer in 2011 from ENAC (Ecole Nationale de l'Aviation Civile) in Toulouse, France. She received her PhD in 2015 from the Department of Mathematics, Computer Science and Telecommunications of the INPT (Polytechnic National Institute of Toulouse), France.

Denis Laurichesse is a member of the navigation system service at CNES. He has been in charge of the DIOGENE GPS orbital navigation filter, and is now involved in navigation algorithms for GNSS systems. He is currently in charge of the CNES IGS real time analysis center. He was the co-recipient of the 2009 ION Burka award for his work on phase ambiguity resolution.

Hanaa Al Bitar is a GNSS systems engineer at Thales Alenia Space France (TAS-F). She is currently the technical manager of the GEO E5b PPP demonstration. She received her Ph.D in RadioNavigation in 2007 from the ENAC, in Toulouse, France, in the field of GNSS Receivers. She joined TAS-F in 2012. Her main activities focus on GNSS receivers signal processing, and EGNOS Land Earth Stations (NLES) signal processing and design.

Mathieu Raimondi is currently a GNSS systems engineer at TAS-F. Raimondi received a Ph.D. in signal processing from university of Toulouse (France) in 2008. Since then, he has been working on various GNSS topics. He joined TAS-F navigation business unit in 2011.

Pierre Lesage is a GNSS systems engineer at Thales Alenia Space France (TAS-F). He graduated as a Telecom engineer from INSA Lyon, and then studied Space Communications Systems (SCS Master) at Supaero. He joined Thales Alenia Space in 2015, working on EGNOS.

Arnault Sfeir is currently project manager of GNSS subsystems at TAS-F. He graduated as a Telecom Engineer from ENSEEIHT, Toulouse, and joined TAS-F in 1996 as satellite payloads AIV (Assembly, Integration and Validation) manager for WoldStar PFM & FM2, XM Radio, GE12/14, Hispasat 1D. He subsequently spent four years in French Guyana at the European spaceport as Ariane 5 Telemetry Operations Manager, before managing the IOT (In-Orbit Test) monitoring system for the Globalstar 2 constellation.

Michaël Klein is currently in charge of GNSS subsystems validation and tests at TAS-F. He graduated as a senior technician from CRED IUT-A (Centre de Recherche et de Développement à l'Institut Universitaire de Technologie) in Talence, near Bordeaux. He joined TAS-F in 1996 as a satellite equipment validation and tests conductor for Globalstar 1, Arabsat, Hyspasat, Worldstar, etc...

Mathieu Sihrener is the technical expert of the NLES (EGNOS uplink stations) at ESSP since 2009. Specialized in Ground Stations and RadioNavigation Signals processing, he is also in charge of the Signal in Space monitoring in collaboration with the satellites providers. He graduated in 2006 from ENAC (Ecole Nationale de l'Aviation Civile) in Toulouse, France.

Nicolas Ramponi is Project Manager at SES Techcom, a fully owned subsidiary of SES, a world-leading satellite operator in Luxembourg. Nicolas joined SES in 1998 as a Multimedia Software Team Leader working on SES satellite communications platforms. In 2008, he became Project Manager at SES Techcom, leading ESA and EU projects in the domain of maritime surveillance such as Automatic Identification System (AIS) via satellite. Since 2011, Nicolas is currently the project manager of two EGNOS hosted payloads services on SES GEO satellites SES-5 and ASTRA 5B. He leads the SES teams for the design and implementation of the EGNOS payloads on these two GEO satellites as well as the associated ground stations and hosting sites. SES-5 and ASTRA 5B satellites are now in operation.

ABSTRACT

Geostationary satellites are a very efficient mean to broadcast information to a large number of users. In the field of navigation they are currently used as Satellite Based Augmentation System (SBAS), GPS augmentation systems like EGNOS (the European SBAS) mainly designed to provide an increased level of accuracy and integrity of GPS based positioning for the benefit of aeronautical safety of life applications. Various other professional domains from agriculture to mapping are also using the SBAS signals with noticeable benefits for the efficiency and the development of these activities. Other augmentation services could be defined with such an approach to provide similar benefits to a wide range of new applications. A good candidate is high accuracy positioning for which there is a long lasting request from users requiring better than a 1m accuracy.

EGNOS recently undertook a major update phase, and currently takes benefits of the entry into service of the new generation of transmitting stations: Navigation Land Earth Station Generation 2 (NLES G2), associated to the SES-5 and ASTRA 5B (its entry into service for EGNOS is expected very soon) satellites from SES, the satellite operator. Both SES-5 and ASTRA 5B host an L1 and an E5 payload. In particular, a bandwidth of 50 MHz is available within the E5 transponder. The lower part (25 MHz) is allocated to the EGNOS L5 (E5a) signal used for the NLES G2. The higher part centred on the E5b frequency is not used by EGNOS Safety of Life (SoL) service (at least at the time when this paper was written).

In previous papers an optimized way to provide an additional service through the available EGNOS GEO payloads has been presented. This definition first resulted from theoretical and simulation results presented in ([1] and [2]). This research analysis hence assessed the opportunity that an L5 SoL service can exist together with a non-SoL service on the E5 repeaters of SES GEO satellites, in using two different NLES: the first one is used to generate the L1-L5 SoL signals, and the other one to generate independently the E5b signal. The latter will be referred to herein as NLES E5b.

In line with previous works on the subject, this paper provides the first LIVE test results of an END-TO-END GEO E5b Precise Point Positioning (PPP) testbed **demonstration** jointly carried out by the French Space Agency (CNES) and Thales Alenia Space, France, with the support of SES Techcom, Luxembourg.

INTRODUCTION

PPP techniques can be defined as a process where a single GNSS receiver can precisely compute its position (down to centimeter level) by autonomously correcting its raw pseudorange and carrier phase measurements using the PPP correction message content. PPP corrections data

include the constellations orbits, clocks, code and phase biases. They are provided to the receiver by different types of communication channels. The PPP enabled receiver handles these corrections in a real time process.

PPP based positioning techniques have been extensively investigated and developed in the last years. These methods are now rather mature and provide a very good mean to achieve in real time a few centimeters of accuracy and precision in remote areas, where other solutions like Real Time Kinematic (RTK) are impracticable or too expensive. One main advantage of PPP approaches is that they provide a global mean to achieve high accuracy based on a global and low density network of base stations. There is no need of a very dense network of stations in the vicinity of the user, which is often impracticable in remote areas.

Although PPP algorithms are the cornerstone of these methods, another important issue for their practical use is the way the PPP corrections can be provided to the user receiver.

So far, typical solutions encompass:

- Internet, using fix or mobile Internet connections like Mobile phone networks (3G/4G). This is a simple solution but suffering of a number of telecommunications issues like discontinuities of the connection, unavailability or bad quality of the transmission in remote areas, and costs or limitations for data transmission. Use of such a mean for PPP broadcast to users would also generate a few GBytes of data transmission per user per month. A generalized use to millions of users (for example in cars) could rapidly exceed the network capacity.
- Satellite based PPP solutions. These channels are more adapted to such a broadcast as not suffering from the above described limitations. Commercial broadcast of such proprietary PPP service by specific Geostationary satellite channels is available [3] but need proprietary receivers and remain expensive, thus limiting its use. Broadcast using other satellite orbits is also experimented on Highly Elliptic Orbits (HEO) on QZSS system for instance [4], [5], or planned with the Commercial Service (CS) on Galileo constellation.

The figure below shows an example of a PPP service broadcast architecture using a satellite link.

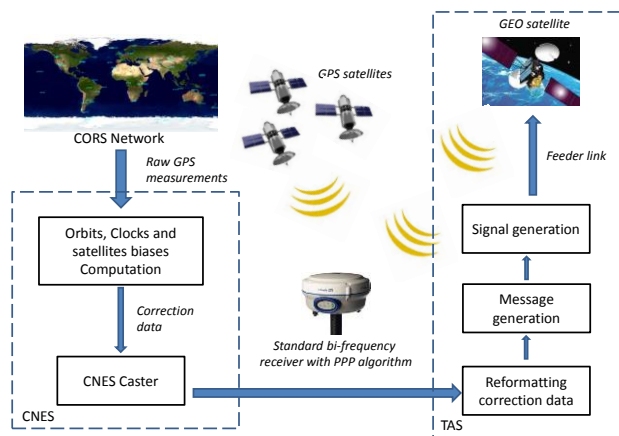

Figure 1 – PPP service architecture through satellite [6]

Complementarity Between MEO and GEO Based PPP Solutions

A demonstration of the PPP message being broadcast on the Galileo E6 central frequency was carried out in [7], and showed that broadcasting a PPP message through Medium Earth Orbit (MEO) satellites is meaningful.

However, it also showed the weaknesses of such scheme:

- A relatively high time latency decreasing the positioning performances;
- A low availability of the E6 message;

Adding a Geostationary Orbit (GEO) PPP broadcast channel to a Galileo MEO E6 channel has the following advantages:

- A higher overall availability thanks to both frequency and spatial diversity. Indeed, the E6 frequency band is not part of the Aeronautical and Radio Navigation Satellite Service (ARNSS) band, and is inherently more subject to interferences than the E5b band. On the other hand, considering different types of environments, GEO signals may be masked in harsh environments like urban or deep urban situations. As GEO satellites are stationary, the receiver has to be in an unmasked area towards the GEO. Another solution would be to involve differential measurements in the masked area with a second receiver. In such environments, MEO satellites have a clear advantage. It has to be noted that usually in urban areas, PPP is also accessible via wireless Internet access such as 3G or Wi-Fi. In open sky environments, the GEO satellites have the advantage of providing a continuous service available in the whole GEO footprint;
- A higher geographical coverage thanks to the combination of MEO and GEO coverage, as

MEO satellites offer higher latitudes coverage compared to GEO coverage;

- A higher data rate, as the PPP message can be broadcast with an incremental precision using both the E5b and E6 bandwidth. Using the GEO E5b bandwidth could alleviate the needs of bandwidth on GALILEO MEO E6 for high accuracy service, thus letting more room for other commercial services like authentication service.

Most importantly, and apart from this end user service complementarity between MEO and GEO satellite based PPP solutions, the today available E5b channel on EGNOS GEO satellites may be used in the future for several Galileo E6 CS testing ends. This is especially true as it is possible to use existing receivers compatible with Galileo E5b signals, to process the PPP message by applying only a firmware update of the receiver, which greatly simplifies the needed infrastructure and thus allows for early testing of different possible Galileo E6 CS functionalities.

In this context, the paper proposes to evaluate the feasibility of broadcasting a GNSS value-added information signal via the E5b EGNOS GEO satellites signal, through a demonstration aiming at evaluating the obtained positioning performances in real conditions.

The demonstration principle consists in broadcasting an E5b signal containing value-added information into an ad-hoc user segment, using the SES SBAS payload capacity to repeat such a signal. The value-added data incoming in real time from a CNES hosted internet server are encapsulated in a message and signal structure similar to the one of Galileo E5b.

The demonstration implements a test-bed, with the generation of a value-added information E5b signal, and at least one GNSS receiver. To achieve the demonstration's goals, a two-steps approach is being followed.

First, a proof of concept is performed, using a laboratory test bed. This test bed emulates the whole link, from the internet server to the E5b receiver in conducted mode, thanks to a GNSS signal simulator, including a real time E5b GEO capability, and a bent-pipe Radio Frequency (RF) payload emulator to simulate the effects of a GEO SBAS payload.

Then, a demonstration using real signal is conducted. The E5b signal is broadcast by the NLES in real time, sent to the SES GEO satellite, and finally received by a GNSS receiver.

It is worth noting that both steps were conducted in real time.

Thales Alenia Space with the support of SES Techcom implemented a preliminary demonstration of this capacity in early 2015. A second window of opportunity to broadcast the PPP signal through an EGNOS GEO payload was available in July 2016.

Following the context and demonstration presentation, this paper will describe the detailed test-bed architecture and will present results firstly obtained in factory and then in on-site real time configuration.

GEO E5b SIS CHARACTERISTICS

GEO E5b SIS Structure

The E5b GEO signal centre frequency is set to 5767.14 MHz for the uplink (NLES-to-Satellite RF link), and to 1207.14 MHz for the downlink (Satellite-to-users broadcast RF link). This is the same centre frequency as the one used for the Galileo E5b signals. The figure below shows the frequency plan used for this testbed, the resulting measured uplink EGNOS + PPP spectrum on site, and the spectral separation between the EGNOS L5 signal and the PPP E5b one. A complete analysis of this spectral separation and interactions between the 2 signals was assessed in [1].

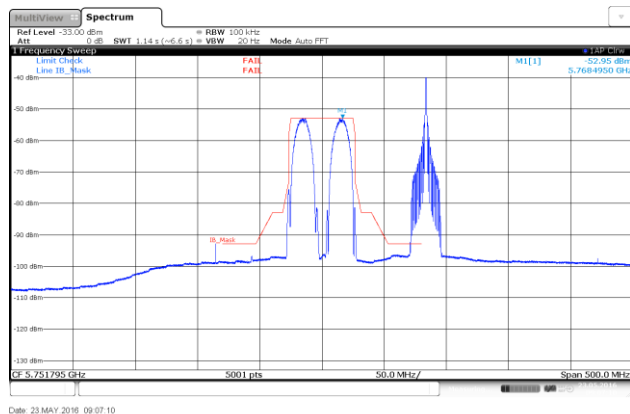

Figure 2 – E5b testbed frequency plan

The modulation used to generate the E5b signal is also the same as the one used for the nominal Galileo E5b signal, defined in the Galileo Open Service Signal In Space Interface Control Document (OS SIS ICD) [8]. Namely a BPSK(10) modulation is used on two quadrature channels : a data and a pilot one. The data rate is the same as for Galileo E5b (250 sps).

The ranging codes are built from so-called primary and secondary codes by using a tiered codes construction, described in paragraph 3.2 of Galileo OS SIS ICD.

The signal's primary and secondary codes comply with the E5b ranging codes characteristics. The Galileo PRN 38 as defined in the Galileo ICD is used. This PRN is not part of the Galileo PRNs that are affected to Galileo

satellites. Secondary codes CS4₁, CS100₈₈ defined in the OS SIS ICD are allocated to the E5b GEO signal data and pilot components respectively.

The next tables summarize the GEO E5b SIS structure and main RF characteristics.

Table 1: E5b GEO RF properties

Carrier Frequency (MHz)	Receiver reference bandwidth (MHz)	Polarization	Reference carrier phase
1207.140 (downlink)	20.46	RHCP	0
5767.14 (uplink)			

Table 2: E5b received power levels on ground

Signal component	Total received minimum power (dBW)	Total received maximum power (dBW)
Total power I+Q	-163	-157

Table 3: PRN codes allocation

Primary code	Secondary code
38	CS4 ₁ , CS100 ₈₈

It is important to note that usually the PPP corrections need a large bandwidth in order to achieve good performances, and especially when providing corrections for several satellite constellations. Obviously, limiting the required data bandwidth is always necessary, due to the high cost of this scarce resource. But limiting the bandwidth may impact the resulting PPP performances such as solution accuracy and convergence time and the availability of PPP service to users. Thus a trade-off has usually to be found between these two constraints.

For this demonstration, innovative compression techniques developed by the CNES were used to be able to broadcast PPP corrections with the data rate available on one E5b Galileo like signal, i.e. 125 data bit / sec, yet keeping very good final accuracy and convergence time performances, as shown in the results presented in this paper. These compression techniques are briefly described in the next paragraph.

GEO E5b PPP Message Characteristics

The E5b PPP message has the same structure as the Galileo E5b I/NAV message. The only difference is that the useful data bits of the Galileo E5b I/NAV message are replaced by the PPP corrections Radio Technical Commission for Maritime (RTCM) message, as described in the next figure.

Each I/NAV page is built as follows:

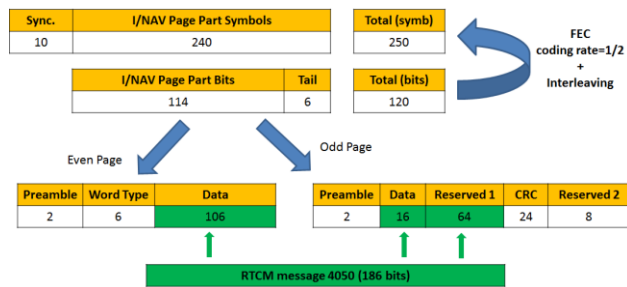

Figure 3 – Construction of I/NAV pages from RTCM data

In the frame of this PPP demonstration campaign, the word type is set to 63, thus indicating a dummy message.

The PPP correction message contents are generated by the so-called CNES caster.

Indeed, in the framework of the International GNSS Service (IGS) Real Time Service (RTS) [9], CNES provides GNSS augmentation data in real-time. These data include the constellations orbits, clocks, code and phase biases. The main goal of the participation in the IGS RTS for CNES is to promote a new precise point positioning technique that performs undifferenced ambiguity resolution [10, 11]. It allows the positioning of an isolated receiver at the centimeter level accuracy in real-time.

In the IGS RTS, the dissemination of the different quantities is performed by means of an open standard, the RTCM. The quantities are defined in a State Space Representation (SSR) [12], by opposition to other techniques like RTK, which use an Observation State Representation.

The following table contains the different RTCM/SSR messages used by the CNES PPP demonstrator and available on the CLK91 mountpoint:

Table 4: RTCM/SSR messages

Constellation	Nature	Type	Occurrence (sec)
GPS	orbits/clocks	1060	5
GPS	code biases	1059	5
GPS	phase biases	1265	5
Glonass	orbits/clocks	1066	5
Glonass	code biases	1065	5

The RTCM standard is primarily designed for terrestrial communications and not with a very low bandwidth in mind. For example, the above-mentioned stream has a bandwidth of several Kbits/sec, and is clearly not compatible with the bandwidth of the I/NAV E5b message of 186 bits every 2 seconds. Thus, an efficient

compression scheme and a new message format need to be designed.

In order to compress the initial RTCM stream by a factor of 50, several ingredients are used. The chosen solution (inspired by other augmentation message like the ones used in SBAS [16] or JPL-GDGPS [17]) is a trade-off between the available bandwidth and corrections latency, while maintaining the main characteristics of PPP, including ambiguity resolution:

- Selection of a reduced set (20) of satellites over the area of service (namely the European continent in this case). The satellites are selected upon their visibility and sorted by their elevation.
- Suppression of the code biases messages. Indeed, as the PPP is mainly a phase solution, code biases are not needed. In the user solution, code measurements are underweighted.
- Phase biases are directly applied to the clocks and do not need to be transmitted.
- Finally, each I/NAV message comprises:
 - o A ‘slow’ part containing orbit corrections, their first order derivative, a raw clock and the widelane bias, for one satellite.
 - o A ‘fast’ part containing accurate clock correction for 4 satellites.

With 4 clocks corrections transmitted every 2 seconds, the set of 20 satellites clocks is actualized every 10 seconds. The entire cycle for the orbit corrections is 40 seconds.

The compression module takes as input the CLK91 stream and sends the compressed stream to a new mountpoint created for this purpose on the CNES caster. It is then possible to access the compressed stream by simply pulling the new stream from the caster.

Figure 4 below shows the gain in bandwidth brought by the compression algorithms, as measured by the independent BNC [14] tool: the improvement is clearly visible.

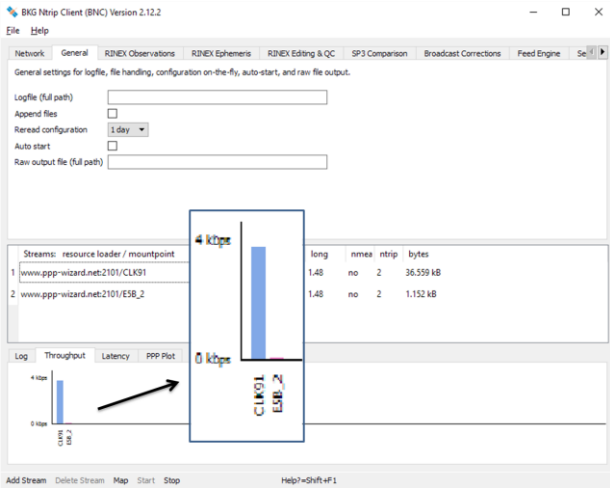

Figure 4 – Compressed stream bandwidth

On the user side, the PPP-Wizard open source software (version 1.2) is used [13]. This tool is compatible with the RTCM real-time stream available at the IGS Real Time Service and provides centimeter accuracy in real time. It has been modified to support the decoding of the new compressed stream.

GEO E5b SIS Generation Scheme

The GEO E5b SIS is generated by an earth station that is independent from EGNOS NLES. Only 2 one way links between the EGNOS NLES and the E5b generation earth station were still needed in this PPP demonstrator for:

- A 10 MHz input to the different E5b GEO SIS earth generation station components
- And a 1PPS input for some of these components

These two links were maintained for the sake of E5b earth station complexity and cost reduction.

The different E5b earth station possible architectures were thoroughly discussed in [1].

DEMONSTRATION SETUP

Prior to satellite transmission experimentations, a comprehensive set of factory tests have been performed.

The on-site demonstrator setup for live tests is first described. It is then followed by a description of specific setup related to factory tests ensues.

On Site Setup

This section details the on-site setup. The demonstration took place in July 2016 at Betzdorf, Luxembourg, on the SES site.

The PPP corrections are provided by the CNES PPP caster. Then, in the NLES E5b, the PPP corrections are encapsulated in the Galileo E5b message format, and generated via a Galileo E5b signal, with the PRN code 38. For the demonstration, the signal is uplinked via the C5 frequency on the SES ASTRA 5B GEO satellite, and finally, the Galileo E5b signal is broadcast via this GEO satellite over Europe, via the E5b frequency.

A commercial off-the-shelf (COTS) receiver is based at Toulouse in order to receive the Galileo E5b signal with the PPP corrections, broadcast by the GEO ASTRA 5B satellite. To be able to use these PPP corrections, the user also needs GNSS constellations measurements. In this demonstration, the PPP corrections for Glonass and GPS are used. Thus, the receiver needs to receive the GNSS measurements from GPS and Glonass constellations.

The E5b demonstrator functional architecture is shown in Figure 5.

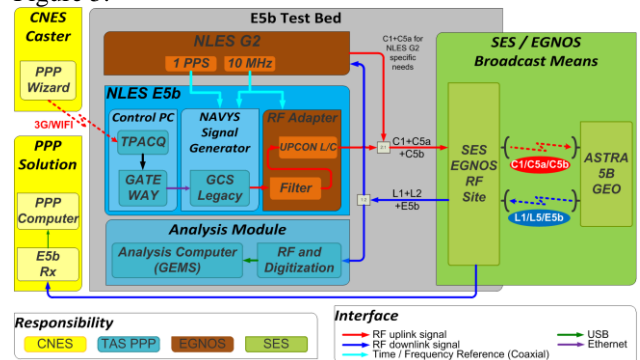

Figure 5 – On-site GEO E5b PPP demonstrator setup for live tests

The demonstrator is composed of:

- The **CNES PPP caster**, in charge of the provision the PPP corrections via internet,
- The **NLES E5b**, in charge of the Galileo E5b signal, in which the PPP corrections are encapsulated (figure 6 below),



Figure 6 – NLES E5b (NAVYS, L-to-C band frequency converter, Analogic filter, RF adapter)

- The **NLES G2**, in charge of the provision of time (PPS) and frequency (10 MHz) references to the NLES E5b, along with the generation of the EGNOS L1 and L5 signals,
- The **SES broadcast means**, in charge of the broadcast of the signals (EGNOS L1 and L5, and Galileo E5b) over Europe via the GEO ASTRA 5B satellite,
- An **E5b analysis module**, in charge of the verification of the emitted Galileo E5b signal,
- A **PPP solution module**, in charge of the reception of the Galileo E5b signal, in addition with the GPS and Glonass measurements, in order to compute the PPP solution.

The **CNES PPP caster** provides PPP corrections via an Internet connection. Detailed information on the CNES PPP caster can be found in [15].

The **NLES-E5b** Control PC has two main functions:

- It manages the data interface by communicating with the CNES caster,
- It manages the real-time interface with the NAVYS signal generator, by sending the real-time data message to NAVYS appropriately formatted.

These functions are performed by:

- TPACQ (standing for Thales PPP ACQuisition): in charge of the connection to the remote server, the extraction of the payload, its convolutional encoding, the construction of a Galileo I/NAV like format, managing the latency, and of providing a data message each and every second,
- GATEWAY: in charge of receiving the messages and writing them in the GCS hard drive. It sends commands to the GCS, writes synchronization commands and writes the navigation message.

The RF interface is managed by the NLES-E5b RF Adapter elements. This RF interface is configured based on the given SES RF interface requirements, and the GSA downlink signal quality and characteristics requirements. It allows for controlling the output signal center frequency, power, bandwidth, in and out of band interference, etc.

The RF adapter is composed of:

- An RF filter. It is used at the output of the NAVYS generator in order to guarantee that the spectral characteristics of the L5 generated signal are compliant with the needed Safety barriers for the uplink signal.
- An Advantech L to C tunable up-converter, borrowed from the NLES G2 factory platform. This equipment, originally designed to up-convert EGNOS L5 signal in uplink transmission band with the desired

amplification level, perfectly fits the demonstrator needs because of its passband. It performs the L5 to C5b frequency translation of the signal generated by NAVYS.

The **NLES G2** is the new generation of EGNOS NLES embedding the ability to generate L1/L5 dual-frequency GEO signals. As already stated, and in order to have a simplified architecture for the NLES E5b, it is foreseen for this station to share some outputs of the NLES-G2, such as :

- The 10 MHz frequency reference (considering that a very stable atomic clock is used in the NLES-G2),
- The 1 PPS signal.

The **SES broadcast means** include the uplink signal interface and the downlink signal interface.

The uplink signal interface is a one way RF interface carrying the C5b signal to be uplinked to the GEO satellite. The power level must be adjusted so that, at the SES RF interface, the total power level in the C5 band is -5 dBm. Two configurations were adopted during factory tests:

- 1- In the first configuration, both C5 components (C5a, generated by the NLES G2, and C5b generated by the NLES E5b), will be set to -8 dBm. The resulting signal has a power of -5 dBm.
- 2- In the second configuration, the power of the C5b component equals -10 dBm. In order to obtain a resulting signal with a power of -5 dBm, the power of the C5a component must equal -6.5 dBm. This configuration is of high interest as authorities could dislike the idea of reducing the power budget allocated to the Sol component.

The downlink signal interface is a one way RF interface carrying the E5b signal received by the SES RF station from the ASTRA 5B satellite.

The **E5b analysis module** is composed of the TAS software receiver, GEMS, and a specific post-processing analysis tool, developed for the demonstration.

The **PPP solution module** is composed of:

- A GNSS COTS receiver: a PolARx5 from Septentrio with a firmware patch to allow the processing of the Galileo PRN 38,
- A PPP solution computation unit.

The PolARx5 GNSS receiver tracks the GPS and Glonass constellations signals in order to provide dual-frequency GNSS measurements to the PPP solution computation unit. In addition, the receiver tracks the Galileo E5b

signal from satellite PRN38, corresponding to the E5b signal broadcast by the GEO ASTRA 5B satellite. As mentioned before, this E5b signal provides the PPP corrections, associated with the GPS and Glonass satellites and optimized for a user located in the GEO satellite ground track.

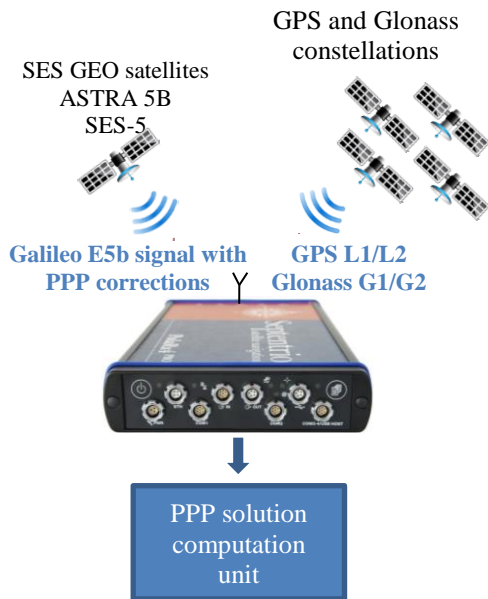

Figure 7 – Demonstration architecture showing the Septentrio PolaRx5 receiver used to demodulate the PPP message

Factory Setup

Prior satellite transmission experimentations, a comprehensive set of factory tests have been performed. The different objectives of this factory test campaign are recalled below:

- Integration of all the demonstrator elements,
- Verification of the feasibility of the demonstration,
- First assessment of the demonstrator performances,
- Demonstration that the demonstrator is compliant with SES requirements,
- Demonstration that the demonstrator does not jeopardize the EGNOS SoL operations.

During factory tests, a so-called GEO Payload Simulator was used to replace the GEO satellite. The GEO Payload Simulator simulated the uplink-GEO-downlink path of both L1 and L5 signals, and was used to generate the E5b signal uplink and downlink paths too.

DEMONSTRATION RESULTS

Factory Live Tests Results

The factory test in TAS premises was performed on 06/15/2016. The conditions of the test were the same as

the ones described on figure 5, except that the GEO satellite was simulated by means of an RF payload simulator.

Figure 8 below shows the error of the PPP, obtained by computing the difference between the PPP module output and the accurate reference coordinates of the receiver antenna, projected in the local frame.

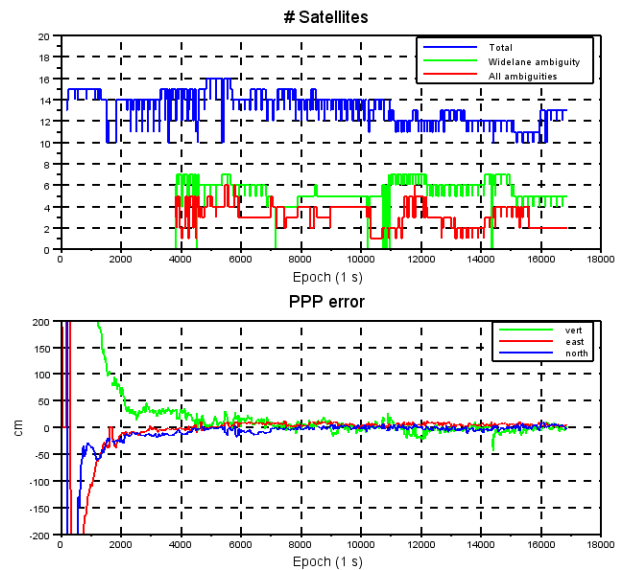

Figure 8 – PPP results during factory tests

These results are representative of a PPP processing: after a first convergence phase of about 1 hour, the accuracy is less than 10 cm. It should be noted that once the convergence step is reached, it is not lost even if the receiver exhibits some dynamics / movements. A number of 14 satellites is typical of the dual-constellation (GPS, Glonass). After convergence, the horizontal accuracy has a Root Mean Square (RMS) error of 7 cm. Up to 6 satellites have ambiguities estimated to their integer value. The overall latency is of about 30 seconds and explains the short term noise of the solution.

This successful result demonstrates the validity of the implementation.

On Site Live Tests Results

The live experiment took place between 21/07/2016 and 27/07/2016.

Several PPP sessions were conducted. The receiver was located on CNES premises, using a geodetic grade antenna on a roof of a building. The NLES E5b was installed on SES site in Betzdorf, Luxembourg together with the NLES G2 for SES ASTRA 5B satellite.

On a typical one-day session (24/07/2016), in the second configuration (the power of the C5b component equals -

10 dBm and power of the C5a component equals -6.5 dBm), PPP results are identical to the ones obtained during the factory tests, in terms of convergence and accuracy:

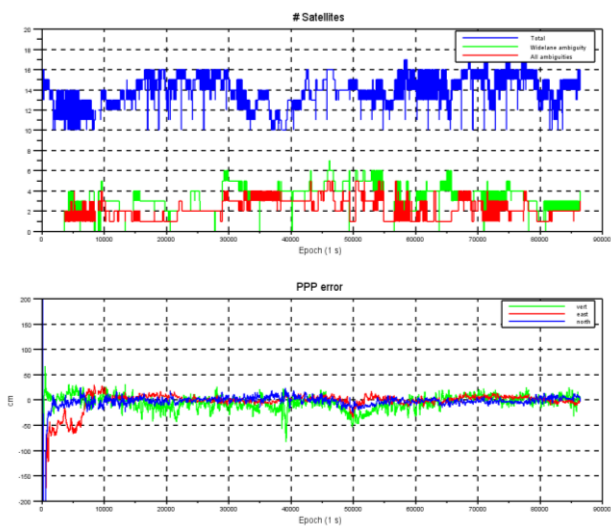

Figure 9 – PPP results during live tests (one day)

After convergence, the RMS of the horizontal accuracy is approximately 8 cm.

The latency measured in this case is of about 23 seconds. Note that this latency is mainly due to this testbed configuration, and will be reduced in any future deployment of such PPP corrections broadcast test.

In order to have a better understanding of the contribution of the GEO transfer function in terms of accuracy, the same measurements were processed using the RTCM real-time corrections, before the stream compression. The results are presented on figure 10:

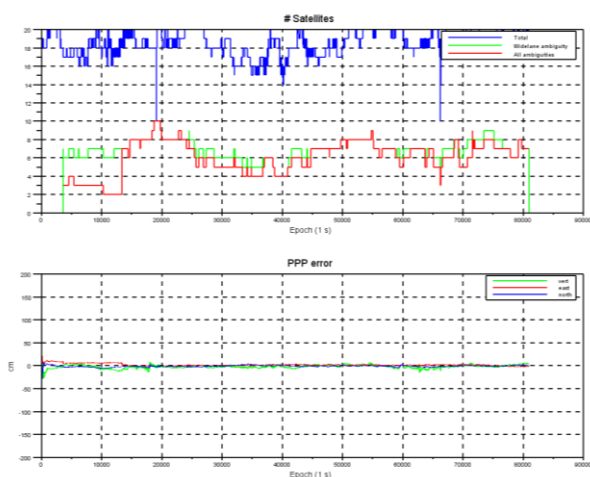

Figure 10 – PPP results without the stream compression (one day)

The horizontal RMS is equal to 2 cm. We can deduce that the noise of the transfer function (compression and end-to-end latencies) is equal to 7.5 cm.

CONCLUSION

This paper is in line and completes the work initiated by CNES and TAS-F on broadcasting value-added information message through the new EGNOS payloads on existing GEO satellites ([1], [2]).

The main and novel quality of this paper is obviously the implementation of a complete end-to-end GEO satellite based PPP solution via real live tests.

A proof of concept was first assessed through a laboratory yet real time testbed.

Next, an on-site real time end-to-end demonstration was held with different levels of implications of the concerned stakeholders (GSA, ESSP, CNES, TAS, and SES).

The success of this demonstration first recalls that an E5b non-SoL signal can co-exist with a SoL one.

Second, and most importantly, the results presented here showed that with only 125 bit/sec data rate available on a Galileo E5b like message, the final accuracy and convergence time performance of the computed solution are still very satisfying (horizontal positioning error = 8cm RMS after a first convergence step of 1 hour, which is a one shot convergence step, i.e. it does not have to be done each time when the receiver moves to another point). For the sake of comparison, the horizontal RMS error is equal to 2 cm when the measurements are processed using the RTCM real-time corrections, before the stream compression.

This testbed further demonstrated that broadcasting an additional signal through an existing and transparent GEO payload requires neither heavy nor complex technical means. It is thus compatible with a possible fast deployment and could allow being a test platform for various functionalities to the upcoming CS E6 Galileo signal for example. This is especially true when further recalling that using an E5b centered frequency signal allows processing such signals using existing receivers with Galileo E5b processing abilities, provided a prior message processing firmware update took place. This was actually the case with the Septentrio PolaRx5 receiver used to perform these tests.

Ultimately, a GEO PPP broadcast channel and a Galileo MEO E6 channel used together could result in an improved accuracy service with better performance, thanks to an enhanced availability (frequency and spatial diversity), a higher geographical coverage and a higher data rate.

ACKNOWLEDGMENTS

We would like to thank the GSA (European GNSS Agency), ESSP and SES engineering and operations teams for their very valuable support to E5b signal testing on SES's EGNOS uplink station and ASTRA 5B EGNOS payload.

We would also like to thank Septentrio for their support in providing a new firmware version of the PolaRx5 receiver allowing tracking a Galileo PRN 38 code.

The content of the present paper reflects solely the authors' view and by no means represents the official CNES views.

REFERENCES

- [1] H. Al Bitar, M. Raimondi, Thales Alenia Space France, L. Ries, CNES, "NLES-NG : Augmenting EGNOS with an E5b Channel", 6th European workshop on GNSS signals and signals processing, Munich, December 2013.
- [2] H. Al Bitar, M. Raimondi, D. Kubrak, Thales Alenia Space France, L. Ries, CNES, "Augmenting EGNOS with an E5b Channel", ION ITM 2014, San Diego, California.
- [3] Otto Heunecke, Hansbert Heister, 2010, "Worldwide kinematic positioning using the OmniSTAR HP and XP services", Institute of Geodesy, University of the Bundeswehr, Munich.
- [4] C H Wickramasinghe, L Samarakoon, 2013, "QZSS LEX message data for precise point positioning", Coordinates, A monthly magazine on positioning, navigation and beyond.
- [5] Ken Harima and al, 2014, "Performance of Real-Time Precise Point Positioning using MADOCAL-LEX augmentation messages", International Federation of Surveyors congress, Kuala Lumpur, Malaysia.
- [6] B. Charlot, H. Delfour, Thales Alenia Space, D. Laurichesse, CNES, P. Lesage, ISAE/ENSEEIH, "Efficient Message Coding To Broadcast PPP Corrections Through Satellite", ISGNSS 2014, ICC Jeju, Korea.
- [7] I. Fernandez, E. C., I. Rodriguez, G. Tobias, J.D. Calle, E. Carbonell, GMV, G. Seco-Granados, Universidad Autonoma de Barcelona, J. Simon, R. Blasi, GSA, "Galileo's Commercial Service, Testing GNSS high Accuracy and Authentication", Inside GNSS, January/February 2015
- [8] Galileo OS SiS ICD
- [9] <http://www.igs.org/rts>
- [10] A.J.Van Dierendonck, and al., "Relationship between Allan Variances and Kalma Filter parameters", Proceedings of the 16th Annual Precise Time and Time Interval (PTTI) Applications and Planning Meeting, NASA Goddard Space Flight Center, pp 273-293
- [11] D. Laurichesse, F. Mercier, J.P. Berthias, P. Broca, L. Cerrri, "Integer Ambiguity Resolution on Undifferenced GPS Phase Measurements and its Application to PPP and Satellite Precise Orbit Determination", Navigation, Journal of the institute of Navigation, Vol. 56, N° 2, Summer 2009SC-159, "Minimum operational performance standards for global positioning system/wide area augmentation system Airborne equipments", RTCA DO 229 D, december 13, 2006, Annex A.
- [12] D. Laurichesse, A. Privat, "An Open-source PPP Client Implementation for the CNES PPP-WIZARD Demonstrator", ION GNSS 2015, Tampa, Florida
- [13] D. Laurichesse, "The CNES Real-time PPP with undifferenced integer ambiguity resolution demonstrator", Proceedings of the ION GNSS 2011, September 2011, Portland, Oregon
- [14] <https://igs.bkg.bund.de/ntrip/download>
- [15] <http://www.ppp-wizard.net>
- [16] www.rtca.org
- [17] JPL GDGPS message: www.rtigs.net/rtigswg/doc/berne.doc